

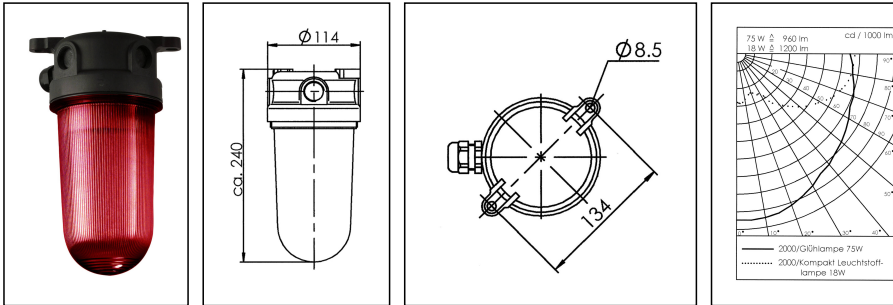

2000/E27/rd

Multi-purpose light



Products may differ in size, colour and appearance to those shown. If you require further information or customisation, please contact us directly.



| | |
|----------------------------------|---|
| WISKA-Order no. | 10015010 |
| Type | 2000/E27/rd |
| Material globe/diffuser | Polycarbonate |
| Material | PBT |
| Globe colour | Red |
| Power[^] | 1 x 75 W |
| Wattage | 75 W |
| Voltage | 230 V |
| Protection class | IP68 (2,0 bar 30min) |
| Temp. range min | -30 °C |
| Temp. range max | 45 °C |
| Lampholder | E27 |
| Number of lampholder | 1 items |
| Lightsource | variable, Incandescent lamp |
| Lightsource incl. | No |
| Bulb shape | Rod shaped |
| Material cable gland | Polyamide |
| Type of cable gland | ESKV 20 PLUS / 7,5-14mm |
| Using for cable gland |  |
| Ø cable diameter min | 7,5 mm |
| Ø cable diameter max | 14 mm |
| External dimensions LxWxH | 134x240mm |
| Weight | 0,57 kg |
| Approval | RMRS, DNV-GL |
| Colour | Black |

Your Contact:

WISKA UK Ltd.

Unit 7, Hurling Way · St. Columb Major Business Park · TR9 6SX, St. Columb Major, Cornwall · Great Britain

☎ +44-12-08816062 · 📠 +44-12-08816708

info@wiska.co.uk · www.wiska.co.uk

| | |
|----------------------|--|
| Mounting | Ceiling, Upside down, Upside, Surface mounting |
| Equipment | 4 threaded knockout entry M20 |
| Tariff number | 85318070 |

Equipment:

- Plastic: impact resistant, heat-and water resistant
- 4 threaded knockout entries M20
- Separate terminal to loop the armour
- 2 cable glands ESKV 20 enclosed separately

Recommended accessories

| | |
|---------------------------------------|----------|
| 2099 Wall bracket | 10015550 |
| SP-Vibration damper light 2000 | 22000912 |

Spare parts

| | |
|--|----------|
| SP-2080 Structured globe red | 22000199 |
| SP-2000 ST/E27 Baseplate | 22000278 |
| SP-2000 Housing M20 | 22000382 |
| SP-Incandescent lamp 60W 230V E27 | 22000983 |

20.05.2024

Your Contact:

WISKA UK Ltd.

Unit 7, Hurling Way · St. Columb Major Business Park · TR9 6SX, St. Columb Major, Cornwall · Great Britain

☎ +44-12-08816062 · 📠 +44-12-08816708

info@wiska.co.uk · www.wiska.co.uk

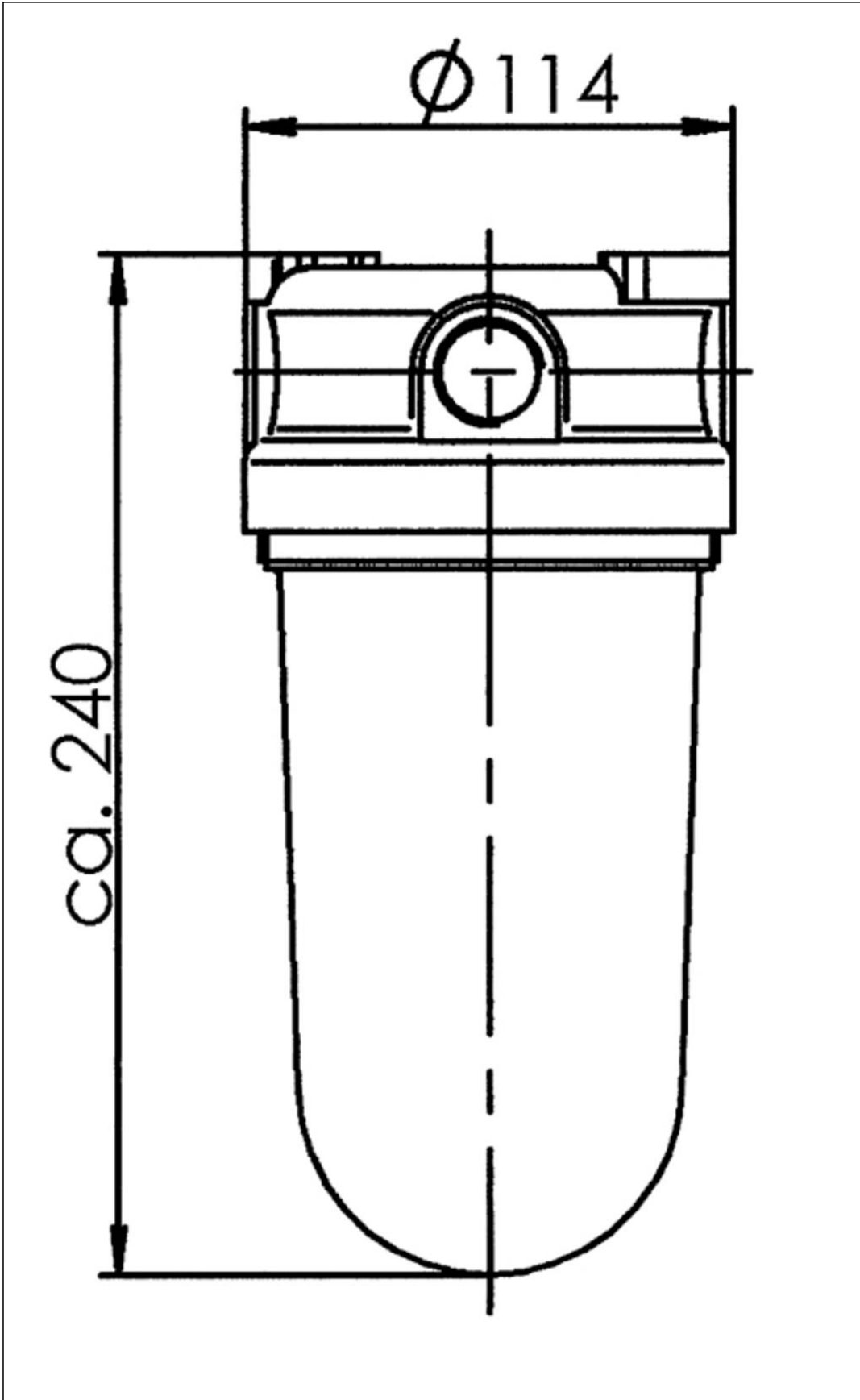

Your Contact:

WISKA UK Ltd.

Unit 7, Hurling Way · St. Columb Major Business Park · TR9 6SX, St. Columb Major, Cornwall · Great Britain

☎ +44-12-08816062 · 📠 +44-12-08816708

info@wiska.co.uk · www.wiska.co.uk

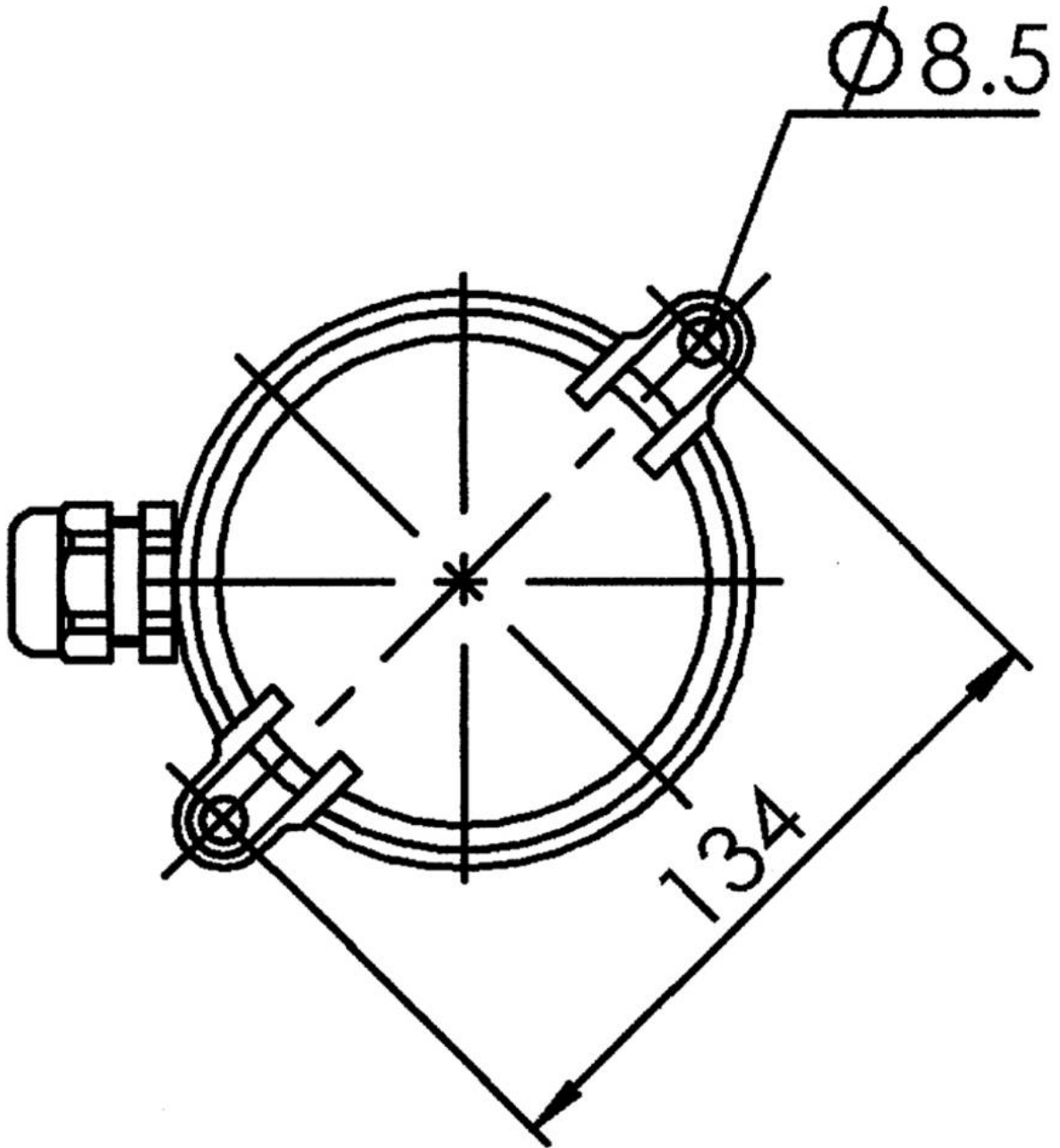

Your Contact:

WISKA UK Ltd.

Unit 7, Hurling Way · St. Columb Major Business Park · TR9 6SX, St. Columb Major, Cornwall · Great Britain

☎ +44-12-08816062 · 📠 +44-12-08816708

info@wiska.co.uk · www.wiska.co.uk

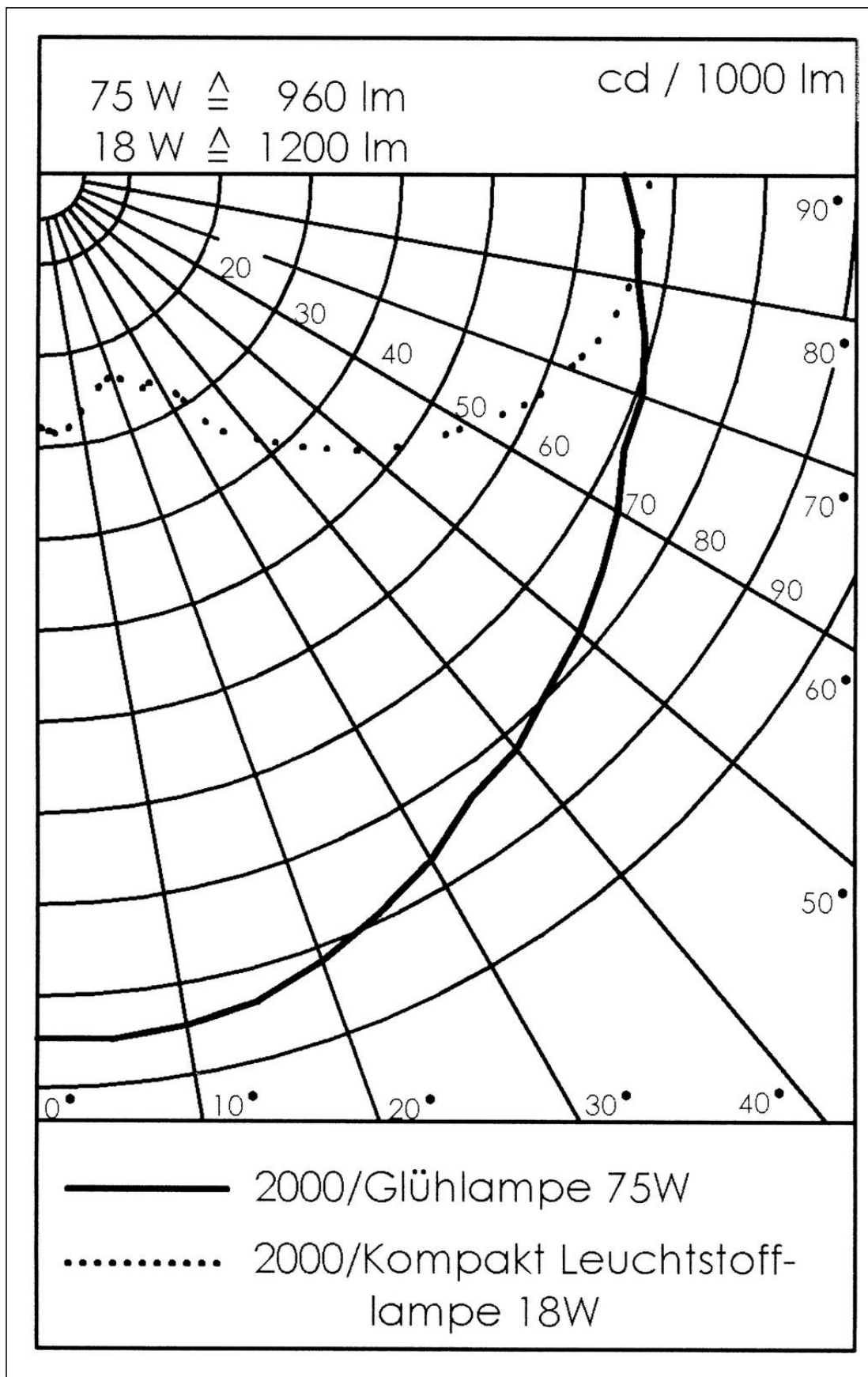

Your Contact:

WISKA UK Ltd.

Unit 7, Hurling Way · St. Columb Major Business Park · TR9 6SX, St. Columb Major, Cornwall · Great Britain

☎ +44-12-08816062 · 📠 +44-12-08816708

info@wiska.co.uk · www.wiska.co.uk