

## 2000/B 220V/AC/gn

Multi-purpose light with flash electronic

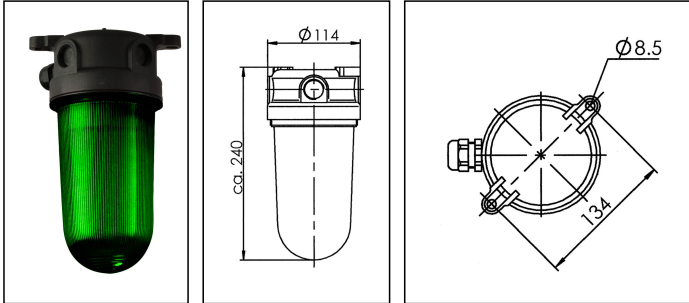

Products may differ in size, colour and appearance to those shown. If you require further information or customisation, please contact us directly.

<b>WISKA-Order no.</b>	10015453
<b>Type</b>	2000/B 220V/AC/gn
<b>Material</b>	PBT
<b>Material globe/diffuser</b>	Polycarbonate
<b>Globe colour</b>	Green
<b>Voltage</b>	220 V
<b>Type of Voltage</b>	AC
<b>Protection class</b>	IP68
<b>Temp. range min</b>	-25 °C
<b>Temp. range max</b>	45 °C
<b>Flash-energy</b>	5Ws 60/Min
<b>Lightsource</b>	Flashlight
<b>Type of cable gland</b>	ESKV 20 PLUS / 7,5-14mm
<b>Ø cable diameter min</b>	7,5 mm
<b>Ø cable diameter max</b>	14 mm
<b>Equipment</b>	4 threaded knockout entry M20
<b>Mounting</b>	Ceiling, Upside down, Upside, Wall, Surface mounting
<b>Colour</b>	Black
<b>External dimensions LxWxH</b>	134x240mm
<b>Weight</b>	0,59 kg
<b>Tariff number</b>	85318070

Equipment:

- Plastic: impact resistant, heat-and water resistant
- 4 threaded knockout entries M20

Your Contact:

**WISKA UK Ltd.**

Unit 7, Hurling Way · St. Columb Major Business Park · TR9 6SX, St. Columb Major, Cornwall · Great Britain

☎ +44-12-08816062 · 📠 +44-12-08816708

info@wiska.co.uk · www.wiska.co.uk

- Separate terminal to loop the armour
- Flash electronic 5Ws (60 flashes/minute)
- 2 cable glands ESKV 20 enclosed separately

## Spare parts

SP-2000 BL 5 W/S 220V Baseplate flash	22000187
SP-2080 Structured globe green	22000198
SP-2000 Housing M20	22000382

20.05.2024

Your Contact:

**WISKA UK Ltd.**

Unit 7, Hurling Way · St. Columb Major Business Park · TR9 6SX, St. Columb Major, Cornwall · Great Britain

☎ +44-12-08816062 · 📠 +44-12-08816708

info@wiska.co.uk · www.wiska.co.uk

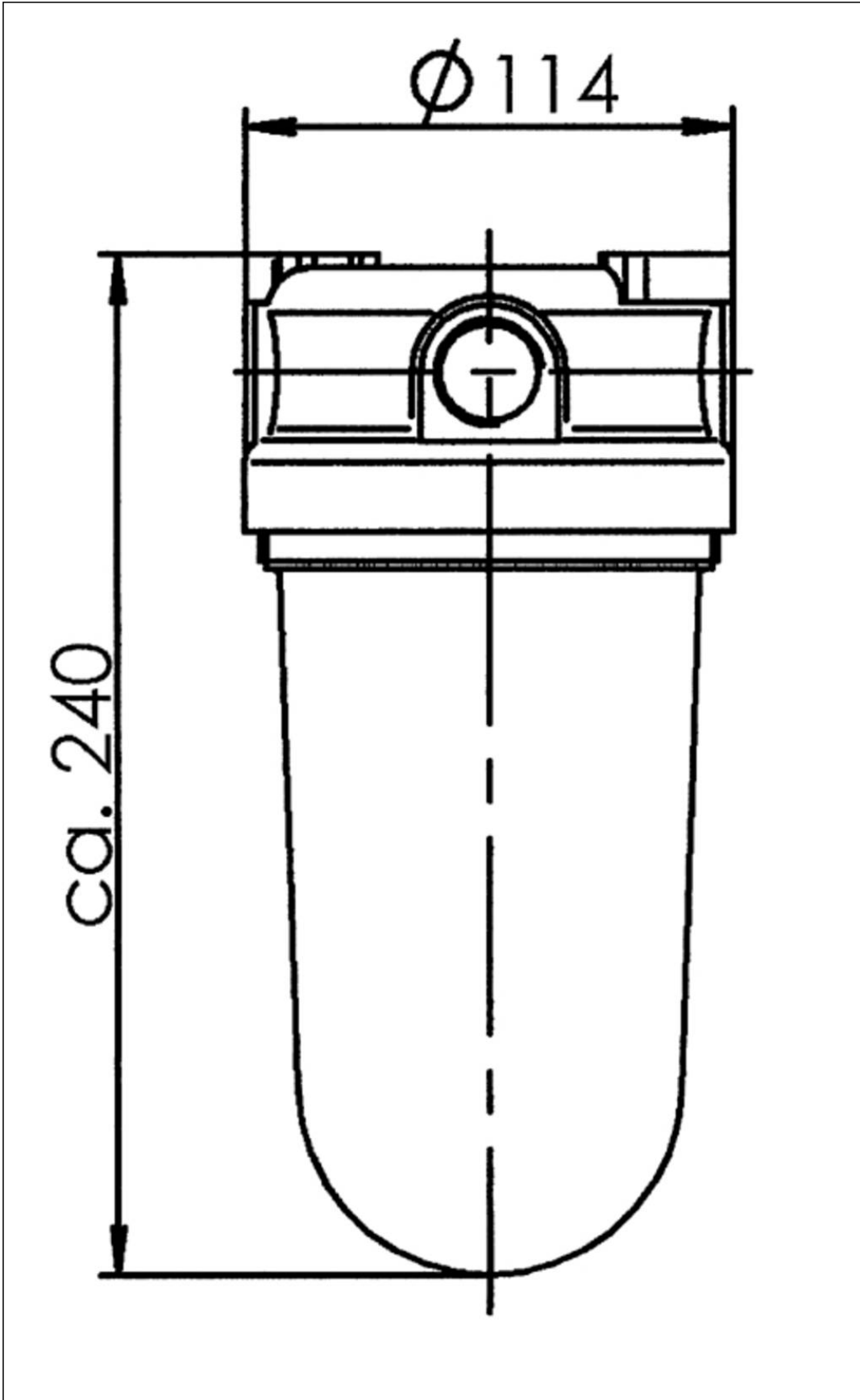

Your Contact:

**WISKA UK Ltd.**

Unit 7, Hurling Way · St. Columb Major Business Park · TR9 6SX, St. Columb Major, Cornwall · Great Britain

☎ +44-12-08816062 · 📠 +44-12-08816708

info@wiska.co.uk · www.wiska.co.uk

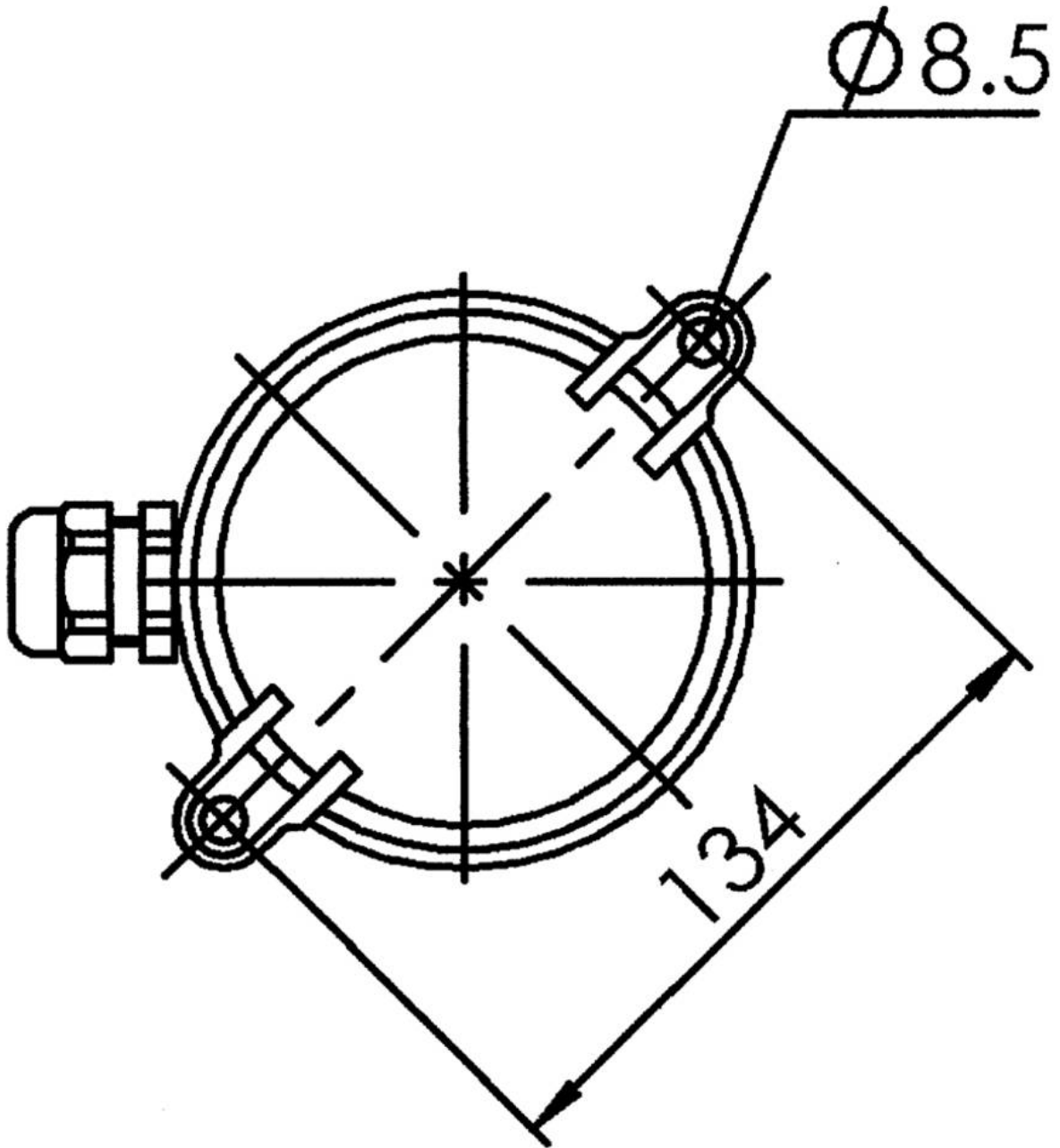

Your Contact:

**WISKA UK Ltd.**

Unit 7, Hurling Way · St. Columb Major Business Park · TR9 6SX, St. Columb Major, Cornwall · Great Britain

☎ +44-12-08816062 · 📠 +44-12-08816708

info@wiska.co.uk · www.wiska.co.uk